

HEAT RECOVERY UNITS

SERIES ASPIRCOMFORT PRO iH

- ➔ Air handling with thermal integration
- ➔ High output heat recovery
- ➔ For integration of heating / cooling.
- ➔ CH193VMC remote panel

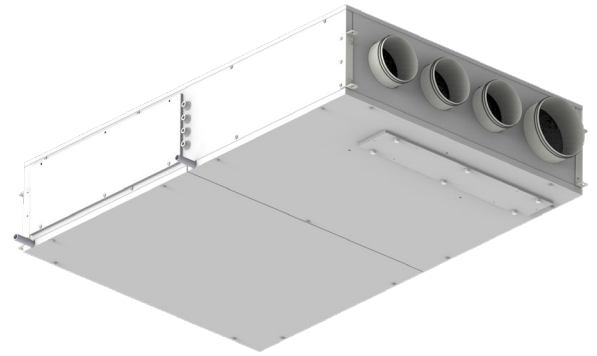

DESCRIPTION:

ASPIRCOMFORT PRO iH is a mechanical fan unit controlled with high efficiency heat recovery unit, air handling section with cooling and heating. The unit is particularly suited for residential, commercial spaces or collective residential buildings and features plug-and-play for quick and simplified installation. The unit is composed of a monoblock which includes every component for correct operation and allows operation with broad outdoor temperature ranges.

CHARACTERISTICS:

- High efficiency counter current polypropylene exchanger >90%. Summer and winter mode.
- Brushless plug-fans with electronic motor and modulating control.
- Very high efficiency and low noise levels. Compliant with directive Erp2018.
- The unit is equipped with a water coil with optimised geometry for integration of cooling and heating. Operation is carried out at various operating temperatures of the feed water.
- PM1 filters on the renewal air and on the stale exhaust air upstream of heat recovery.
- Easily removable coarse filters with low head loss on the recirculation air.
- Double sandwich panelling, unit with external coating and internal aluzink finish.
- Galvanised sheet metal self-supporting perimeter structure. Panel insulation is built with high performance 20 mm-thick insulation and adhesive polyethylene 6 mm-thick insulation.
- Electric panel on-board the unit with microprocessor and dedicated regulation. Fan control, regulation of room temperature and desired room set point. Fan control, display of the temperature probes inside the machine, timed dirty filter control, recirculation management, anti-freeze function and management of the on off valve on the water side. Remote control panel for unit operation with CH193VMC capacitive touch for installation on 503 box; multi-language configuration and user menu; MODBUS RTU RS 485 communication.

UNIT CONFIGURATION

Code	Total flow rate/renewal air flow rate
AP20064	600/150
AP20066	900/250

The ASPIRCOMFORT PRO iH unit with CH193VMC, remote control entails unit operation through a touch remote control with the possibility of selecting the selected room temperature and relative measured temperature;
 3-speed control and automatic operation, turning the unit on and off and display of the filter alarm and temperature probe statuses;
 the control internally manages the bypass, anti-freeze and fan modulation functions and offers external open and close controls of the On/Off valve on the water side and consent to the system generator.

UNIT OPERATION

■ VENTILATION ONLY MODE

The ASPIRCOMFORT PRO iH unit fulfils mechanical ventilation with high efficiency heat recovery. It will be possible to select the fan speeds so as to obtain the desired flow rate to fulfil the air renewal requests.

The selectable flow rates are:
 On size AP20064 from 0 to 150m³/h
 On size AP20066 from 0 to 250m³/h

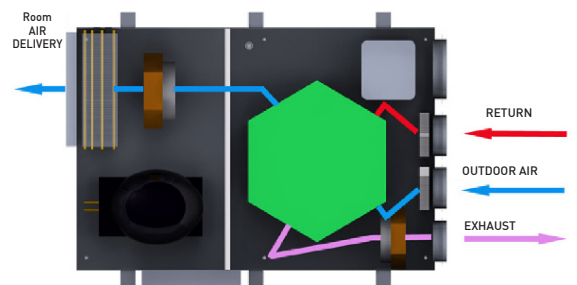

■ VENTILATION AND INTEGRATION MODE

The ASPIRCOMFORT PRO iH unit will continue fulfilling mechanical ventilation with high efficiency heat recovery but will increase the air flow rate, recirculating from the dedicated room air duct to increase the air volume on the integration part. The integration part is composed of a section with hydronic coils.

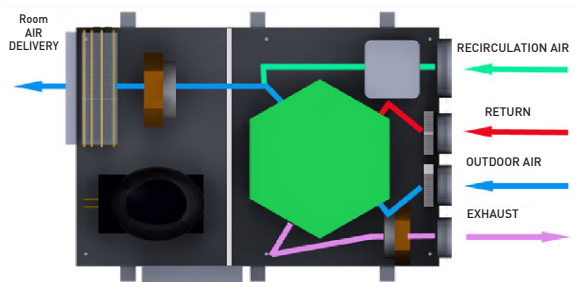

The unit feeds fluid in winter and summer. The coil offers operation with low temperature water in the winter of 45/40 and at medium temperature in summer of 8/10°. Continuous modulation of the fans offers high room comfort level also when heating and cooling the room.

OPERATING LIMITS

HEATING	Indoor Air	Outdoor Air
°C - U%	5° / 30°	-20° / 20°
COOLING	Indoor Air	Outdoor Air
°C - U%	15° / 30°	20° / 45°

UNIT PERFORMANCE

■ GENERAL TECHNICAL DATA

AP20064

AP20066

Recovery unit ¹ rated winter efficiency	%	86.6	86.5
Recovery unit summer rated efficiency ²	%	83	84
Rated outdoor air flow rate	m3/h	151	263
Total air flow rate	m3/h	692	838

(1) Outdoor air temperature 7°; relative humidity 72%. room temperature 20°C; relative humidity 28%, rated air flow rate

(2) Outdoor air temperature 30°; relative humidity 60%. room temperature 25°C; relative humidity 50%, rated air flow rate

■ VERSION with ntegration

Hydronic coil output cooling capacity ²	kW	3.7	5.56
Summer mode water flow rate	m3/h	0.75	0.9
Summer mode head loss	Kpa	18	20
Heat output ³	kW	4.5	6.8
Winter mode water flow rate	m3/h	0.75	0.9
Winter mode head loss	Kpa	18	20
Sound pressure Lp at 3m	dB(A)	42.8	46.2
Electrical power supply	V/Ph/Hz	230 / 1 / 50	230 / 1 / 50
Maximum absorbed current	A	1.8	2.2

(2) Room temperature 25°C; relative humidity 60%, rated air flow rate; Water in 7°C Water out 12°C;

(3) Room temperature 20°C; relative humidity 60%, rated air flow rate; Water in 50°C Water out 45°C;

ECODESIGN CLASSIFICATION

Below is a summary of the classification of the various models according to European regulation 1253/2014 and 1254/2014

AP20064



AP20066



CERTIFICATIONS

The CE marking (applied on each machine) certifies compliance with the following Community standards:

- Low Voltage Directive 2014/35/EC
- Electromagnetic Compatibility Directive 2014/30/EC
- Ecodesign 2009/125/EC

TECHNICAL FEATURES

■ General data

Type of Fans		Backward blade radial - directly-coupled electronic motor - 0/10 V signal
Ventilation air flow rate	m ³ /h	151
Useful pressure	Pa	100
Integration air flow rate	m ³ /h	692
Useful pressure	Pa	100

■ Heat exchanger

Recovery efficiency	%	86.6
Heat output	Kw	4.5
Water Flow Rate	Nr.	0.6
Head loss	kPa	18

■ Summer data

Recovery efficiency	%	83
Cooling capacity	Kw	3.7
Water Flow Rate	M ³ /h	0.6
Head loss	kPa	18

■ Filters

Type of filters	Flat Filters	
Filtration class	Pm1 80% + Coarse	

■ Acoustic data (Data referring to standard UNI EN 3741 and UNI EN 3744)

Sound power L _w generated by the structure	dB(A)	64.8
Sound power L _w irradiated in the duct	dB(A)	67.1
Average sound pressure L _p at 1m	dB(A)	49.8
Average sound pressure L _p at 3m	dB(A)	42.8

■ Electrical Data

Power supply voltage	V	230 / 1 / 50 Hz.
Absorbed current	A	1.8
Protection rating	IP	44

TOTAL FLOW RATE AERAULIC PERFORMANCE

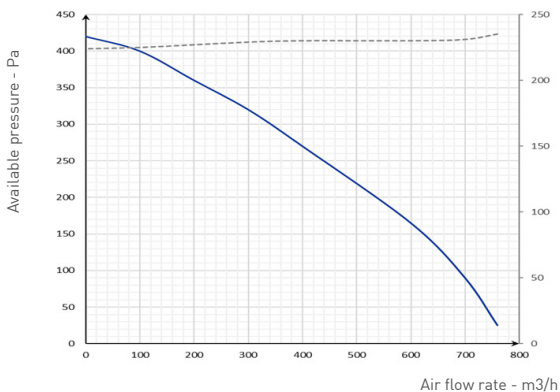

EXHAUST AERAULIC PERFORMANCE

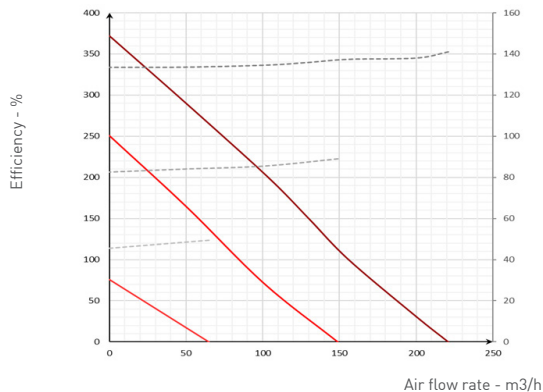

WINTER THERMAL EFFICIENCY [1]

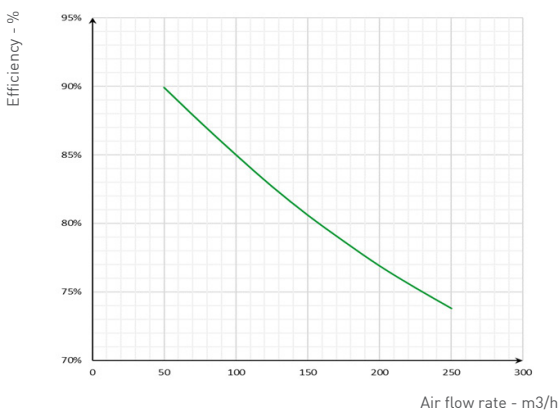

SUMMER THERMAL EFFICIENCY [2]

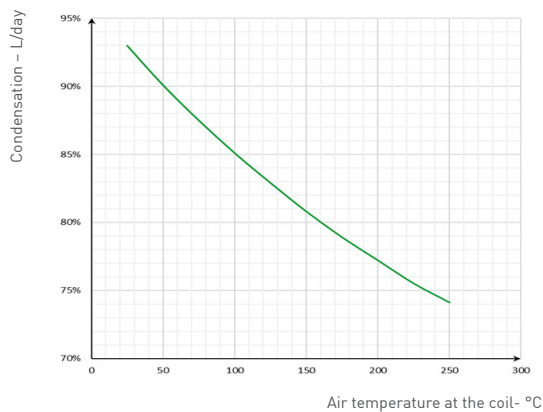

HEAT OUTPUT [3]

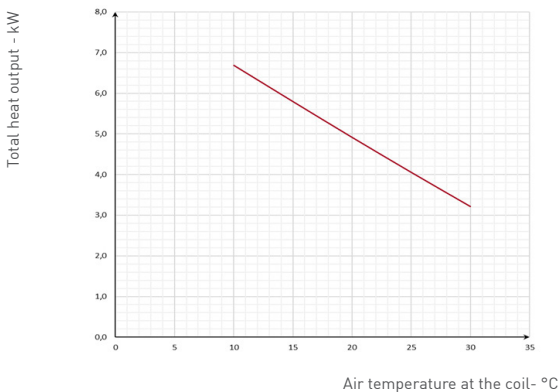

COOLING CAPACITY [4]

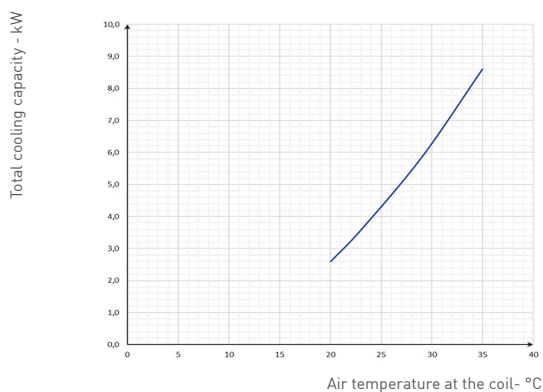

HEAD LOSS/HYDRONIC COIL FLOW RATES

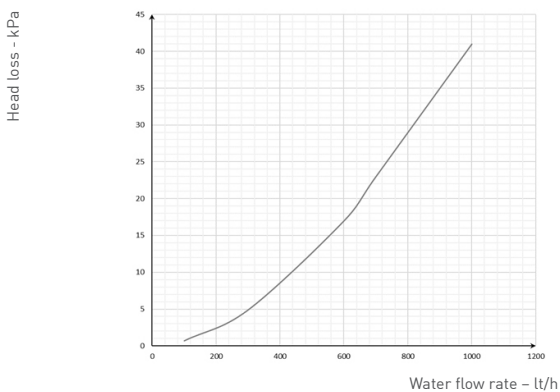

- 1) - Outdoor air temperature 7°; relative humidity 72%.
room temperature 20°C; relative humidity 28%
- 2) - Outdoor air temperature 30°; relative humidity 60%.
room temperature 25°C; relative humidity 50%
- 3) - Room temperature 20°; relative humidity 50%, rated
outdoor air flow rate Water inlet temperature 50°C
- 4) - Room temperature 25°; relative humidity 60%, rated
outdoor air flow rate Water inlet temperature 7°C

			Standard	Vers. with enthalpic recovery unit	
A	Supplier name or trademark		Fantini Cosmi	Fantini Cosmi	
B	Model identification		Aspircomfort PRO650IH	Aspircomfort PRO650IH	
C	Version		AP20064 + Regulator CH193VMC with T, RH, Voc, CO2eq	AP20064 + Regulator CH193VMC with T, RH, Voc, CO2eq	
	SEC	Kwh/m2	COLD	-65.1	-62.70
			AVERAGE	-27.2	-26.20
			WARM	-2.8	-2.70
SEC CLASS		B	B		
D	Declared type		UVR - Bidirectional	UVR - bidirectional	
E	Type of installed drive		Variable speed drive	variable speed drive	
F	Heat recovery system		Recovery	recovery	
G	Heat recovery thermal efficiency	%	86.6	80.60	
H	Maximum flow rate	M3/s	0.041	0.0410	
I	Electric power input at the maximum flow rate	W/h	211	211.0	
J	Sound power level	Lwa	64.8	64.8	
K	Reference flow rate	M3/s	0.029	0.0294	
L	Reference pressure	Pa	50	50	
M	SPI	W / m3/h	0.781	0.7540	
N	Control factor	CLTR	0.85	0.85	
O	Declared maximum leak percentages	%	5.1 ext. / 5.3 int.	5.1 ext. / 5.3 int.	
Q	Position and description of the signal relative to the filter		Shown on the remote control display and on the instructions manual	Shown on the remote control display and on the instructions manual	
S	Website for disassembly instructions		www.fantinicosmi.it	www.fantinicosmi.it	

SPECIFICATION ITEM

Fan and air handling unit with very high output heat recovery, compact dimensions for ceiling installation. Specific unit for ventilation in single residential buildings and collective flats with low energy demand combined with heating and cooling systems of the served rooms.

Tested and classified according to Ecodesign European regulation ref. 1253/2014 and 1254/2014.

CONSTRUCTION FEATURES

Double panelling side structure with galvanised sheet metal inside and coated on the outside, with 23mm-thick insulation in between, compact dimensions and reduced height for straight forward installation with easily accessible lower panel for maintenance and inspection.

Circular inlets with sealing gasket for connection to air ducts.

Quick tool-free filter inspection and double discharge for condensation exhaust with trap supplied.

Hydronic coil for operation in heating and cooling with broad thermal exchange surface.

Electrical board, excluded from the air flow with control boards and control terminal boards.

Backward blade radial centrifugal fans with low consumption electronic speed control EC motors.

Polypropylene counter current flow static heat exchanger for very high recovery efficiencies of the sensitive (standard configuration) or enthalpic heat (code AP20390 mod. RCH-366/160).

ePM1 class filters with low outdoor air and stale air head loss, Coarse on recirculation.

ADJUSTMENT

Electric panel on-board the unit with microprocessor and dedicated regulation. Fan control, display of the room temperature, timed dirty filter management, recirculation and renewal air control, On/Off water valve control. Remote panel CH193VMC with touch graphic interface for selecting operating mode, temperature setting and desired speed. Equipped with temperature, relative humidity and air quality sensors for the control and modulation of the operating speed. Control and management of dehumidification and heating and cooling integration coils. Semi-recessed model in 503 box.

DIMENSIONS AND FUNCTIONAL SPACES

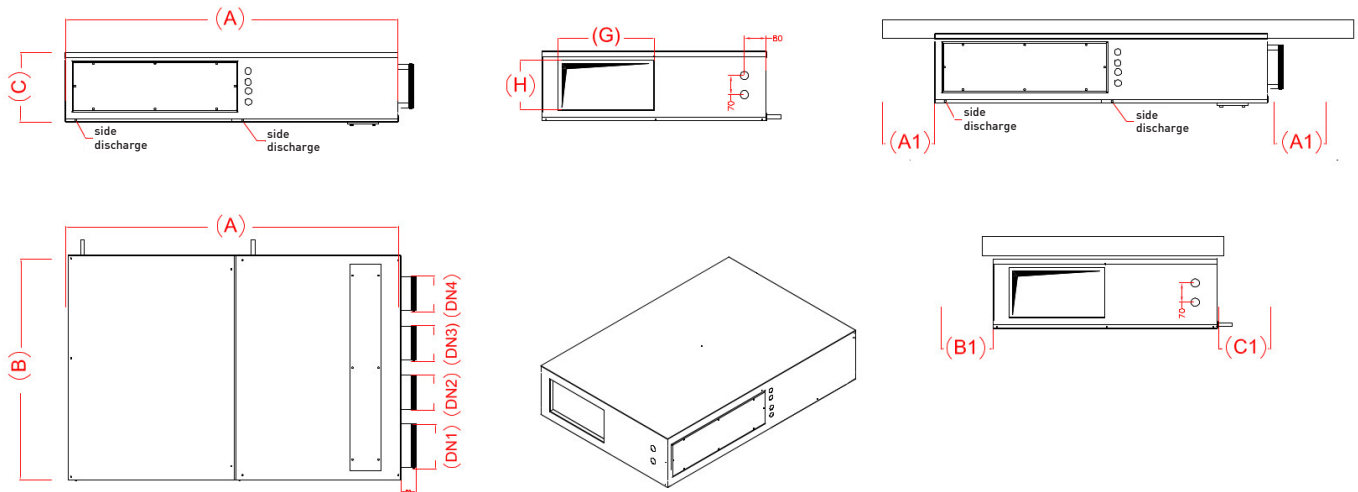

Width A	mm	1220
Depth B	mm	820
Height C	mm	255
Recirculation air inlet DN1	mm	200
Stale air inlet DN2	mm	125
Renewal air inlet DN3	mm	125
Stale air exhaust DN4	mm	125
Supply b x h	mm	550x180
A1	mm	30
B1	mm	30
C1	mm	300
Supply/return water connections	∅	3/4" – 3/4"
Condensation	∅	20
Weight	kg	74

TECHNICAL FEATURES

■ General data

Type of Fans		Backward blade radial - directly-coupled electronic motor - 0/10 V signal
Ventilation air flow rate	m ³ /h	263
Useful pressure	Pa	100
Integration air flow rate	m ³ /h	838
Useful pressure	Pa	100

■ Heat exchanger

Recovery efficiency	%	86.5
Heat output	Kw	6.8
Water Flow Rate	Nr.	0.9
Head loss	kPa	20

■ Summer data

Recovery efficiency	%	84
Cooling capacity	Kw	5.56
Water Flow Rate	M ³ /h	0.9
Head loss	kPa	20

■ Filters

Type of filters		Flat Filters
Filtration class		Pm1 80% + Coarse

■ Acoustic data (Data referring to standard UNI EN 3741 and UNI EN 3744)

Sound power L _w generated by the structure	dB(A)	67.8
Sound power L _w irradiated in the duct	dB(A)	69.9
Average sound pressure L _p at 1m	dB(A)	53.6
Average sound pressure L _p at 3m	dB(A)	46.2

■ Electrical Data

Power supply voltage	V	230 / 1 / 50 Hz.
Absorbed current	A	2.2
Protection rating	IP	44

TOTAL FLOW RATE AERAULIC PERFORMANCE

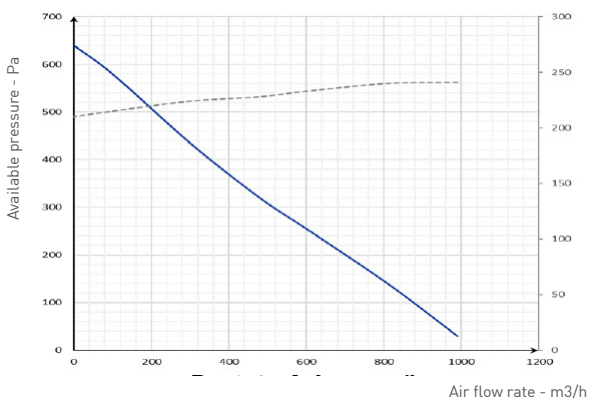

EXHAUST AERAULIC PERFORMANCE

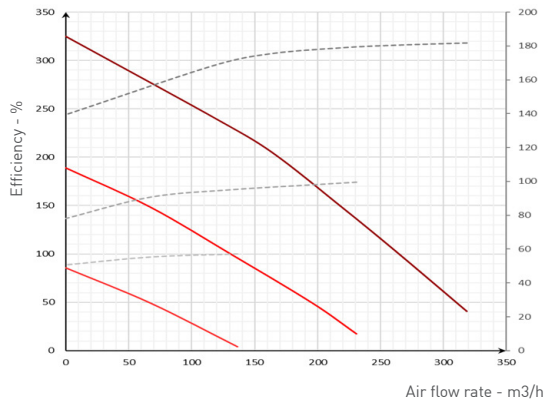

WINTER THERMAL EFFICIENCY [1]

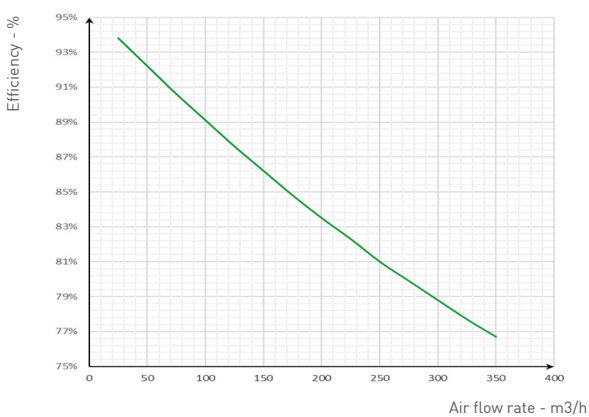

SUMMER THERMAL EFFICIENCY [2]

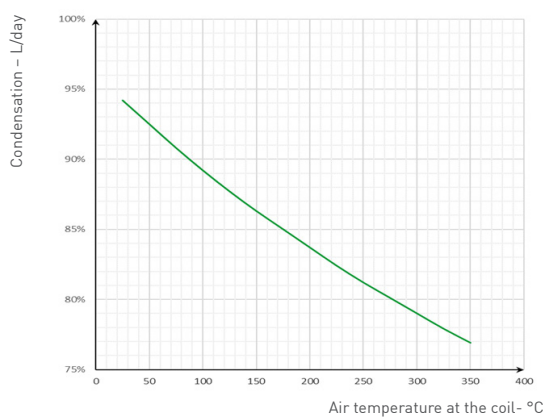

HEAT OUTPUT [3]

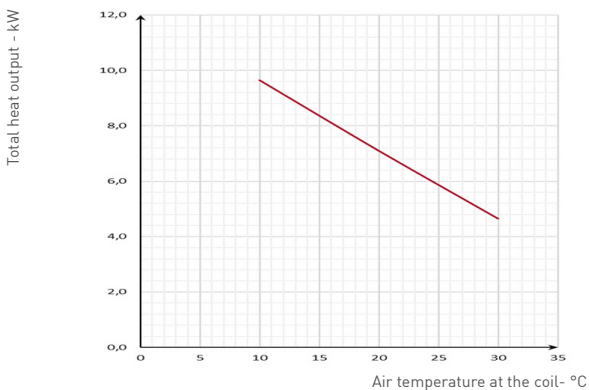

COOLING CAPACITY [4]

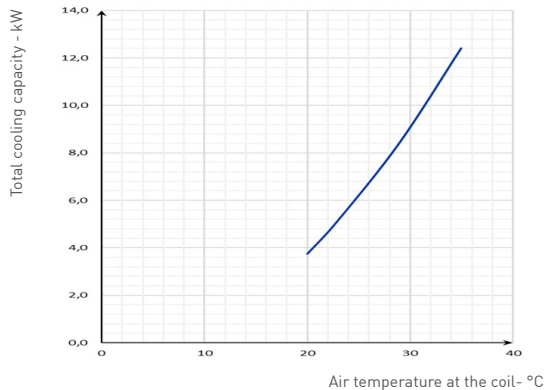

HEAD LOSS/HYDRONIC COIL FLOW RATES

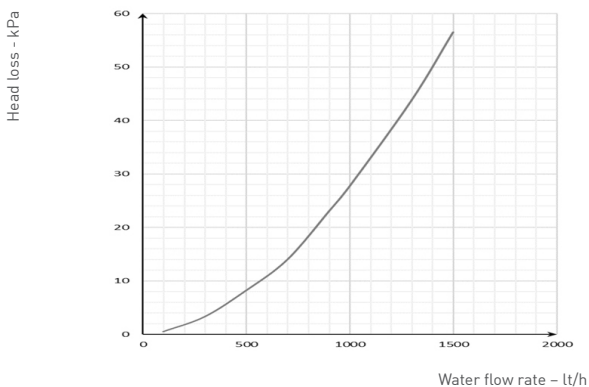

- 1) - Outdoor air temperature 7°; relative humidity 72%. room temperature 20°C; relative humidity 28%
- 2) - Outdoor air temperature 30°; relative humidity 60%. room temperature 25°C; relative humidity 50%
- 3) - Room temperature 20°; relative humidity 50%, rated outdoor air flow rate Water inlet temperature 50°C
- 4) - Room temperature 25°; relative humidity 60%, rated outdoor air flow rate Water inlet temperature 7°C

			Standard	Vers. with enthalpic recovery unit	
A	Supplier name or trademark		Fantini Cosmi	Fantini Cosmi	
B	Model identification		Aspircomfort PR0950IH	Aspircomfort PR0950IH	
C	Version		AP20066 + Regulator CH193VMC with T, RH, Voc, CO2eq	AP20066 + Regulator CH193VMC with T, RH, Voc, CO2eq	
	SEC	Kwh/m2	COLD	-69.3	-66.35
			AVERAGE	-31.3	-29.93
			WARM	-6.9	-6.44
SEC CLASS		B	B		
D	Declared type		UVR - Bidirectional	UVR - bidirectional	
E	Type of installed drive		Variable speed drive	variable speed drive	
F	Heat recovery system		Recovery	recovery	
G	Heat recovery thermal efficiency	%	86.5	86.50	
H	Maximum flow rate	M3/s	0.073	0.0730	
I	Electric power input at the maximum flow rate	W/h	255	255.0	
J	Sound power level	Lwa	67.8	67.8	
K	Reference flow rate	M3/s	0.051	0.0520	
L	Reference pressure	Pa	50	50	
M	SPI	W / m3/h	0.602	0.5880	
N	Control factor	CLTR	0.85	0.85	
O	Declared maximum leak percentages	%	4.8 ext. / 4.9 int.	4.8 ext. / 4.9 int.	
Q	Position and description of the signal relative to the filter		Shown on the remote control display and on the instructions manual	Shown on the remote control display and on the instructions manual	
S	Website for disassembly instructions		www.fantinicosmi.it	www.fantinicosmi.it	

SPECIFICATION ITEM

Fan and air handling unit with very high output heat recovery, compact dimensions for ceiling installation. Specific unit for ventilation in single residential buildings and collective flats with low energy demand combined with heating and cooling systems of the served rooms.

Tested and classified according to Ecodesign European regulation ref. 1253/2014 and 1254/2014.

CONSTRUCTION FEATURES

double panelling side structure with galvanised sheet metal inside and coated on the outside, with 23mm-thick insulation in between, compact dimensions and reduced height for straight forward installation with easily accessible lower panel for maintenance and inspection.

Circular inlets with sealing gasket for connection to air ducts.

Quick tool-free filter inspection and double discharge for condensation exhaust with trap supplied.

Hydronic coil for operation in heating and cooling with broad thermal exchange surface.

Electrical board, excluded from the air flow with control boards and control terminal boards.

Backward blade radial centrifugal fans with low consumption electronic speed control EC motors.

Polypropylene counter current flow static heat exchanger for very high recovery efficiencies of the sensitive (standard configuration) or enthalpic heat (code AP20391 mod. RCH-366/270).

ePM1 class filters with low outdoor air and stale air head loss, Coarse on recirculation.

ADJUSTMENT

Electric panel on-board the unit with microprocessor and dedicated regulation. Fan control, display of the room temperature, timed dirty filter management, recirculation and renewal air control, On/Off water valve control. Remote panel CH193VMC with touch graphic interface for selecting operating mode, temperature setting and desired speed. Equipped with temperature, relative humidity and air quality sensors for the control and modulation of the operating speed. Control and management of dehumidification and heating and cooling integration coils. Semi-recessed model in 503 box.

DIMENSIONS AND FUNCTIONAL SPACES

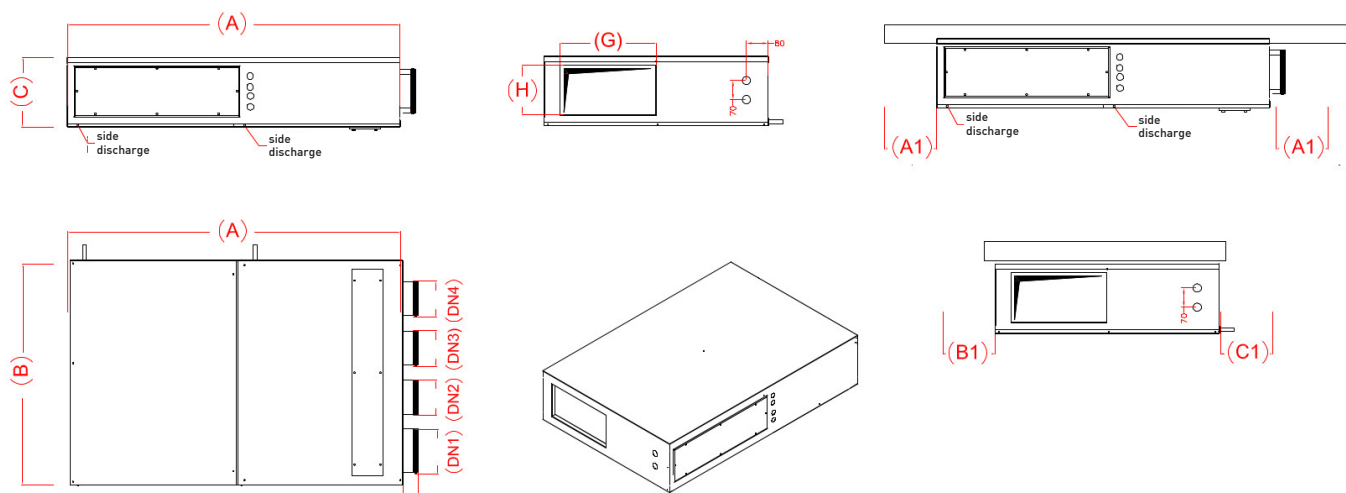

Width A	mm	1220
Depth B	mm	960
Height C	mm	330
Recirculation air inlet DN1	mm	250
Stale air inlet DN2	mm	160
Renewal air inlet DN3	mm	160
Stale air exhaust DN4	mm	160
Supply bxh	mm	490x255
A1	mm	30
B1	mm	30
C1	mm	300
Supply/return water connections	∅	3/4" - 3/4"
Condensation	∅	20
Weight	kg	89

ADJUSTMENT (Mandatory)

CH193VMC - REMOTE CONTROL

Semi-recessed touch screen remote control for installation on 503 box;

Speed control and operating modes;

Equipped with temperature, relative humidity and air quality sensor for automatic control of VMC speed. Control and management of dehumidification and heating and cooling integration coils.



ACCESSORIES

■ AERAULIC

DIRECT SUPPLY PLENUM OF HOSES SIZE 60 /15

Supply plenum with 5 Dn125mm circular inlets

Flanges for securing to the unit.

Polyethylene internal insulation.



PL6 - DIRECT SUPPLY PLENUM OF HOSES SIZE 90/25

Supply plenum with 5 Dn125mm circular inlets

Flanges for securing to the unit.

Polyethylene internal insulation.



DIRECT SUPPLY PLENUM OF 12 CORRUGATED PIPES SIZE 60/15

Supply plenum with 12 front inlets + 8 side inlets for DN75 / DN90 mm connection



P20350 - DIRECT SUPPLY PLENUM OF 12 CORRUGATED PIPES SIZE 90/25

Supply plenum with 15 front inlets + 8 side inlets for fitting DN75 / DN90 mm



AP20364 - DIRECT SUPPLY PLENUM FOR MANIFOLD REMOTE CONTROL SIZE 60/15

Supply plenum with 1 circular Dn200mm inlet for remote control of supply manifold

Flanges for securing to the unit.

Polyethylene internal insulation.



AP20366 - DIRECT SUPPLY PLENUM FOR MANIFOLD REMOTE CONTROL SIZE 90/25

Supply plenum with 1 circular Dn250mm inlet for remote control of supply manifold

Flanges for securing to the unit.

Polyethylene internal insulation.

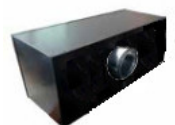

AP20390 RCH-366/160

ENTHALPIC HEAT EXCHANGER FOR AP20050-AP20052-AP20060-AP20064

Cross flow counter current enthalpic heat exchanger for heat and humidity recovery.

AP20391 RCH-366/270

ENTHALPIC HEAT EXCHANGER FOR AP20054-AP20062-AP20066

Cross flow counter current enthalpic heat exchanger for heat and humidity recovery.

UNIT ORDER CODES

Models with high efficiency exchanger

CODE	Model	Description
AP20064	ASPIRCOMFORT PRO 650iH	Heat recovery unit, for horizontal installation, with flow rate of 150 m ³ /h
AP20066	ASPIRCOMFORT PRO 950iH	Heat recovery unit, for horizontal installation, with flow rate of 250 m ³ /h
CH193VMC		Touch screen remote control (ordered separately)

