

# CENTRIFUGAL FANS

## AC 100 SERIES

- ➔ for duct application
- ➔ wall and ceiling installation



Ø 80 mm

### DESCRIPTION:

The compact and pleasant design, the performances and silent functioning mode, together with the practical front cover clip-on system and the tear-proof system of the power cable, make the ASPIRSIMPLEX fan line extremely simple and practical to be installed.

The 80 mm diameter exhaust duct makes the application of these products even more versatile. The butterfly shutter prevents the return of smoke and odours in the environments and the particle filter for grease, dust, etc., are certainly important complements for these high quality products. Using ball bearing motors in the AC100-PLUS models, make them even more reliable in their operating time.

### MAIN FEATURES:

- Adapter ring for outlet holes Ø100 mm Ø120 mm, supplied.
- AC100-PLUS models motors are equipped with bearings.
- Made of shockproof and heat resistant plastic (ABS).
- Induction motor - Is Class B - 2100 RPM with self-lubricating bushings.
- Motor protection through a thermal fuse.
- Signal lamp for operation.
- 2 protection filters, supplied.



IPX4 CE

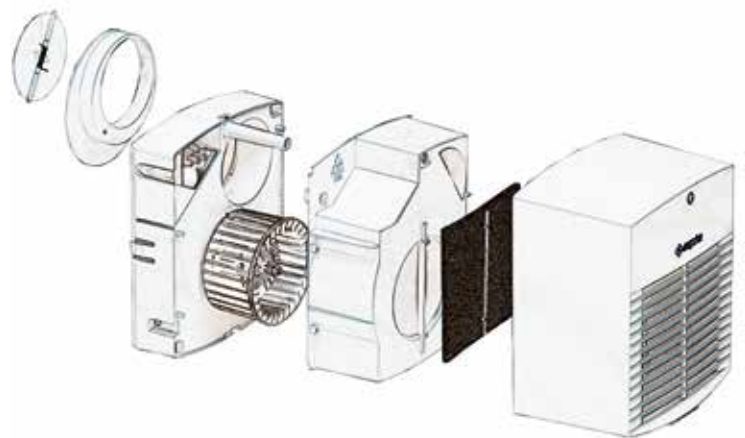

### SPARE PARTS:

- Acrylic filter for retaining the solid particles (grease, dust, etc.).

## DIMENSIONS

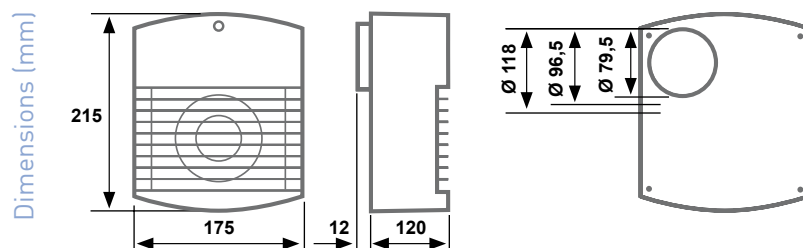

## TECHNICAL SPECIFICATIONS

### STANDARD - S

CODE	MODEL	m <sup>3</sup> /hr	Pt max mmH <sub>2</sub> O	V	Hz	W	dB(A) 1,5mt	Kg
AP1388	AC 100 S	90	12	230	50	30	43	1,55
AP1453	AC 100 S-PLUS	90	12	230	50	30	43	1,55

### WITH ACTIVATION THROUGH A CORD SWITCH- PC

CODE	MODEL	m <sup>3</sup> /hr	Pt max mmH <sub>2</sub> O	V	Hz	W	dB(A) 1,5mt	Kg
AP1420	AC 100 PC	90	12	230	50	30	43	1,55

### WITH ELECTRONIC TIMER - T

The fan starts to operate when the light switched on and it continues to work for a programmable period of time between 45 seconds and 30 minutes, after the light is switched off.

CODE	MODEL	m <sup>3</sup> /hr	Pt max mmH <sub>2</sub> O	V	Hz	W	dB(A) 1,5mt	Kg
AP1396	AC 100 T	90	12	230	50	30	43	1,55
AP1461	AC 100 T-PLUS	90	12	230	50	30	43	1,55

### WITH AUTOMATIC HUMIDITY CONTROL- HTT

The fan automatically starts to operate when the relative humidity level in the room exceeds the pre-set value and it continues to work until the RH level returns below the pre-set threshold. When this threshold is reached, TIMER function allows the fan to continue operating for a programmable period of time between 45 seconds and 30 minutes, to further reduce the relative humidity value in the room. The relative humidity value RH can be set from a minimum of 40% RH to a maximum of 80% RH. This fan can be used manually, also using the TIMER function.

CODE	MODEL	m <sup>3</sup> /hr	Pt max mmH <sub>2</sub> O	V	Hz	W	dB(A) 1,5mt	Kg
AP1412	AC 100 HTT	90	12	230	50	30	43	1,55
AP1487	AC 100 HTT-PLUS	90	12	230	50	30	43	1,55

## SPARE PARTS

CODE	MODEL
AP2212	12 FILTERS AC100

# CHARACTERISTIC CURVES

## AC100 SERIES

